

**ADDENDUM NO. 2**

**MAIN LIFT STATION RENOVATIONS PROJECT  
Letts, Iowa**

**Bids Due and Opened: 4:00 PM, May 28, 2026**

Attn: Main Lift Station Renovations Project-Letts IA  
510 State Street, PO Box 560  
Tiffin, IA 52340  
(319) 545-7215

The Plans and Specifications prepared for this project are hereby modified, amended or clarified as follows:

**A. SPECIFICATIONS**

1. SECTION 260970

Article 2.02. C. 2.; Change article to read

Autodialer system is to be Crystal Ball Plus, by OmniSite, or approved equal. The Contractor shall furnish and install the autodialer system in compliance with the manufacturer's recommendations. See attached manufacturer's specifications. All existing control boxes, panel boards, pumps and equipment are to be salvaged and taken to a City designated area for storage.

2. SECTION 260950

Article 2.02 A 8.

Change specified meter to read Optiflux 2000 by Krohne.

**B. VALIDITY OF BID:**

**PLEASE NOTE:**

In order for the Bid to be valid, the receipt of Addendum No. 2 must be acknowledged in the appropriate space on the **FORM OF PROPOSAL**.



  
\_\_\_\_\_  
Benjamin A. Carhoff, P.E.  
Iowa Registration No. 19939  
My license renewal date is December 31, 2027

22 May, 2026  
Date



# Crystal Ball Plus Engineer's Specification

## **Part 1: General**

**A.** The contractor shall furnish, install and place into operation a comprehensive monitoring and control system for the water treatment facilities as described herein. All equipment is to be completely factory assembled, wired and tested prior to shipment. The system shall be Crystal Ball Plus™ Series as manufactured by OmniSite, Inc

**B.** The naming of manufacturer in this specification is not intended to eliminate competition or prohibit qualified manufacturers from offering equipment. Rather, the intent is to establish a standard of excellence for the material used, and to indicate a principle of operation desired. The base bid shall be the specified Omni-site equipment. Alternate proposed systems shall be submitted to the owner at least 14 days prior to bid (in accordance with the following presubmittal requirements.) Acceptable alternate equipment is listed below:

- Allen Bradley
- Automation Direct
- Dataflow
- VTSCADA

**C.** Not less than (100%) of all equipment shall be standard catalogued products of the pumping system supplier to assure one source responsibility, proper system interconnections and reliable, long-term operation. The pump supplier shall provide all control equipment and employ full-time engineering, service and support personnel necessary to provide and support the complete system.

### **1.03 System Coordination and Single Source Responsibility**

**A.** The equipment provided shall be a completely integrated automatic monitoring and control system consisting of the required power equipment (circuit breakers, transformers etc.), automation and alarm monitoring equipment in a factory wired and tested assembly. The automatic control and alarm/monitoring system components shall be standard, cataloged, stocked products of the pump system supplier to assure one source responsibility, immediately available spare/replacement parts, proper system interconnections and reliable long term operation. The entire system software will be fully configurable by the owner, using a simple fill-in-the-blank configuration method. Systems that require trained programmers, or factory software setup and configuration for future software edits will not be acceptable.

## **1.04 Drawings**

- A.** The complete assembly shall be provided with job-specific wiring diagrams, parts lists, enclosure dimensional and door layout drawings and instructions, provided by the pump supplier.
- B.** Shop Drawings shall be submitted for approval for all equipment herein specified. The Shop Drawing Submittal shall include a Document List. An Order Specification shall be included which shall describe in detail all equipment provided. Each panel shall be provided job-specific wiring diagrams, parts list, enclosure door layout and enclosure dimension drawing. The wiring diagram requirement applies to all field mounted instruments, control and telemetry equipment as well as all required interfacing to the power panel. Interconnection details shall be shown for all field mounted instrumentation. A description of Operation shall be provided detailing the operation of the complete system, including the telemetry, control and alarm handling.
- C.** Provide Record Drawings and Instruction Manuals. These manuals shall include corrected Shop Drawings. In addition, a detailed Programming and Operations Manual for the Microprocessor-based Controller Unit shall be included. The manual shall include all information as detailed for the Shop Drawing Submittals above.

## **1.05 Presubmittal Information Required for Alternate Manufacturers**

- A.** Full description and performance data on all substitute items proposed with references or verification of performance for such equipment already in service shall be provided. The PREBID Qualification Submittal shall include the following:
  - B.** A reference project list with a minimum of five (5) reference projects shall be included. The referenced project list shall include the following information for each project listed; project name, a brief description of the project (to include number of locations, communications medium employed and any/all control loops), the name and telephone number for a contact person. All reference projects given shall be web-to-wireless systems including internet based configuration, local back-up pump control and monitoring and personnel identification similar in size and scope to this project.
  - C.** Detailed description of how the proposed substitute differs from that specified including but not limited to materials of construction, fabrication, operation, warranty, service, communications technology, corrosion protection, power consumption and maintenance requirements. A detailed comparison of the Internet based interface and backup pump control must include detailed specification comparisons, and a description of how the proposed system meets and/or exceeds the Omni-site technique
  - D.** Detailed discussion of why the proposed substitute is equal or superior to that specified in material of construction, fabrication, operation warranty, service, corrosion protection, power consumption and maintenance requirements.
  - E.** Tracings and four copies of revised prints reflecting in detail any and all changes in arrangement for materials, equipment, piping, fabrication, erection, maintenance, power supply, etc.
  - F.** Provide a Programming and Operations Manual for the Microprocessor-based controller.

The manual shall include the following information as a minimum:

1. How to view and change between the various displays.
2. Alarm displays and a list of alarms handled.
3. Alarm handling (ISA sequence used, etc.).
4. Status displays and a list of statuses handled.
5. Status Handling
6. Analog control setpoint adjustment and displays.
7. Analog alarm setpoint adjustment and displays.
8. Access code usage.
9. Sequence for OTA Updates to operating system
10. Personnel tracking system description, logging technique and use
11. An example of programming values.
12. Use of the real-time calendar/clock, including changing the time and date.
13. A table for entering the values programmed at the factory.
14. A table for entering the values programmed in the field.
15. Description of proposed web based interface and security features

**G.** Name and telephone number of person (s) to contact to answer questions or supply additional information. **No alternate manufacturers are exempt from presubmittal requirements.**

**H.** Name and telephone number of factory authorized local sales and service personnel. Local factory authorized sales and service personnel must be experienced with the equipment proposed. Provide documentation stating that the factory authorized sales and service personnel have not less than three (3) years experience with the equipment proposed.

**I.** Failure to name an approved manufacturer in each space provided in the proposal will constitute grounds for declaring the bid irregular, or if the Owner chooses, give the prerogative of equipment selection solely to the Owner. If more than one manufacturer is named in any space it will declare that the Bidder has not preference and will give the prerogative of equipment selection solely to the Owner.

**J.** The right is reserved to reject any and all proposals, to waive any informality, irregularity, mistake, error or omission in any proposals received and to accept proposal, as determined by the Engineer or Owner, deemed most favorable to the interests of the Owner.

## **Part 2: Scope**

### **2.01 The Overall Control and Web Based Interface System Shall Perform the Following:**

The Crystal Ball Plus is optimized for advanced pump station control, monitoring, personnel identification, and ease of use. The completed system provides the following standard calculations, presented in a user-friendly graphical format, to be overlaid onto the client's existing, private web-pages.

- Well(s) Level
- Well(s) level high and low alarms
- Personnel Identification station using OmniSite SMART key
- Power Failure
- Well drawdown rate (using automatic timed well drawdown tests)

- Total station flows from timed drawdowns and refill calculations
- Pump-1,2,3 amp draw
- Pump-1,2,3 on/off cycles
- Pump-1,2,3 runtime
- Pump-1,2,3 failure
- Pump-1,2,3 on/off automatic pump control from well(s) level
- Rainfall (if connected to an external rain gauge)
- Daily Time stamps of when alarm events occurred, and who responded
- Cellular signal strength indication
- Alarm notification using e-mail, text message, or voice call, and 2 year notification history
- Historical log showing all alarm history and continuous water level
- Web-based graphs of historical data that can also be exported to Microsoft Word or Excel programs
- Low back-up battery alarm

*TO INCLUDE: (Each Remote Site)*

- 1-Weatherproof 4 X 12 X 10 X 4" polycarbonate enclosure
- 1-Intelligent key reader station
- 1- Operator Interface LCD display and keypad
- 1-Surge Arrestor.
- 1-Crystal Ball Plus™ Remote Telemetry Unit.
- 1-Power supply, charger, backup battery and filter.
- 1-OSMR Cellular Modem.
- 1- Set of slip-on pump amp probes
- 1-15VDC power supply
- 1-Crew on-site intelligent key
- 1- Omnidirectional antenna
- 1- I-Level Submersible Level Transducer by OmniSite

**Remote Site List** – The above standard monitoring list at each remote site shall be accompanied by the following site specific alarm and/or monitoring I/O

- 1) Please fill in the remote sites to be monitored and any additional I/O
- 2)
- 3)
- 4)
- 5)
- 6)
- 7)
- 8)
- 9)
- 10)
- 11)
- 12)
- 13)
- 14)
- 15)

**DETAILED SYSTEM SEQUENCE OF OPERATION: (Each Remote Site)**

Designer – In this area, include an exact sequence of operation that must occur in addition to any standard sequences listed above. If no additional interlocking or control is required, then this section can be deleted

## **Part 3: Products**

### **3.01 Microprocessor-Based Crystal Ball Plus™ Controller**

**A.** A Microprocessor-based Controller Unit shall be provided for monitoring and control of the pump stations based on alarm contact closures, universal voltage input signals, 4-20mA signals, and relay outputs. The cellular and cloud based controller will report historical data to the OmniSite private customers website

**B.** The Microprocessor-based monitor shall be a standard, catalogued product of a water and wastewater equipment manufacturer regularly engaged in the design and manufacture of such equipment. The pump/alarm monitor shall be specifically designed for pumping automation utilizing standard hardware and software. “One of a kind” systems using custom software with a generic programmable controller, or pieces from many manufacturers that are “integrated” together will not be acceptable. The controller shall be Crystal Ball Plus™ as mfg. by OmniSite, Inc.

**C.** The controller shall accept (14) universal DI configurable to monitor dry contacts or any voltage range between 12VDC/VAC to 120 VAC/VDC with two (2) of these inputs convertible to act as pulse counters; (4) 4-20mA isolated analog inputs, (4) 20 amp relay outputs, (1)rain gauge input, and (1) crew on-site intelligent key reader input in its base form. It shall have Wago type removable terminal blocks.

**D.** Gel Cell Battery: On-board 12VDC, 800mAH gel cell battery provides backup for up to 4 hours in the event of power loss. Battery is automatically recharged using temperature compensated floating battery charging circuit.

**E.** Four 20 amp Control Relays: Heavy duty 20 amp control relays are used to control up to 3 pumps and one alarm light/horn based upon water level and includes automatic pump alternation. Pump control relays shall have adjustable control direction, set points, and dead bands. A dedicated “level simulation button” is used to manually activate relays and determine proper operation. Interstart time delays shall be utilized to prevent “slamming-on” all pumps together after a power failure. A dedicated “override” key on the user keypad shall allow simple removal of a pump from automatic control when “out of service”. A third dedicated “level setpoint” key allows simple adjustment of on/off setpoints without the need for laptop computers or complex re-programming

**F.** LCD display: (20 character X 4 line) Liquid Crystal display is viewable in very bright sunlight, total darkness or very high or low temperatures. This high visibility operator display is used to configure and monitor variables and eliminates the need for programming devices such as laptop computers. Includes built-in screen saver that continuously scrolls values of all inputs and calculations for easy viewing and setpoint adjustment

**G.** RS485 port: The LCD display/keypad assembly on the face of the RTU can be remotely mounted. A single cable delivers power and control to this remote mount display. Allows viewing input,

calculation, and alarm information outside of hazardous or restricted areas. The remotely mounted display shall be NEMA 1 rated, and shall include a receptacle to read the intelligent personnel tracking key.

**H.** SD Memory card slot: Trend log data from connected variables shall be stored on the memory stick for later retrieval. Memory shall have the ability to be used for updates to the RTU operating system eliminating the need for field laptop computers to repair operating program errors. Memory sticks available from 32MB to 1GB.

**I.** Intelligent key reader: Intelligent key reader identifies operator on site and logs who visited site, took equipment out of service, etc. Keys can be reprogrammed by the RTU key reader on site, eliminating the need to contact the factory for key re-programming. One RTU key included with each RTU.

### ***3.02 Color Graphic Software and Web-to-Wireless Technology***

The OmniSite Crystal Ball Plus™ RTU is completely, programmed, setup, and configured using a standard web browser at the [www.omnisite.com](http://www.omnisite.com) website. All connected equipment can be monitored and configured from anywhere in the world using the world-wide-web.

Proprietary programming software or skills are not required. Systems that require proprietary programming software, or cryptic telephone interfaces will not be considered. Another significant feature of the Crystal Ball Plus is its ability to be positioned anywhere in the United States without coordination with the local telephone company. There are no long distance telephone charges for equipment located anywhere in the USA. This is a significant feature required by the client allowing them nationwide monitoring capabilities without long-distance telephone charges. Since the Crystal Ball Plus is wireless it can be repositioned by the client at any time in the future without coordination with the telephone company (making it a truly mobile device), and monthly wireless fees are FIXED. Cellular systems that do not provide FIXED monthly fees or incur long distance charges for out-of-state calls will not be considered.

Additionally, the system described herein shall, at no future time, require the addition of radio repeaters, system software re-configuration, or installation of hard-wired telephone lines if a future remote site is added to the network. A future device shall merely "auto-populate" the clients existing data screens eliminating the need for specialized engineering and software creation.

The system software shall provide the following features:

- 1) Upon Alarm condition: facilitate the compilation and transmission of alarm information over 4G cellular to residential or commercial sites, or cellular phones, provide for verbalization of alarm information and allow for the secure remote acknowledgment of such alarms.
- 2) Allows for Voice Dial-in Connection via telephone call to facilitate the Acknowledgment of active alarms.
- 3) Allows for Voice Dial-in Connection via telephone call to facilitate the inquiry of values of digital tags.
- 4) Both Voice Dial-in and Voice Dial-out access modes shall be protected by mandatory password entry system.
- 5) The OmniSite software supplies the unique ability of text-to-speech conversion of typed-in alarm messages so that sound files do not have to be manually recorded. This saves much time and

programming complexity. Systems that do not employ advanced text-to-speech conversion will not be considered.

- 6) Shall allow for the configuration and maintenance of a set of "global" voice data files used in the construction of voice output messages.
- 7) Shall allow for the creation and maintenance of a "phone book" of destinations for alarm transmissions. The quantity of eligibility entries in the phone book shall be unlimited.
- 8) Shall have the ability to archive collected data and export this data to common Microsoft packages.
- 9) Shall provide for the creation of "Groups" consisting of selected entries from the Phone Book. A "Group" may be considered to be a logical grouping of alarms, based upon the type of transmission desired as a result of any alarm condition. Group configuration shall allow for:
  - a) Allow for selection of recipient list for alarm transmissions along with recipient priority determination.
  - b) Allow for creation of user configurable delays prior to commencement of alarm transmissions.
  - c) Allow for user selection of "single pass" or "continuous loop" modes through recipient list until alarms are acknowledged.
  - d) Allow for user enable/disable of: data logging to disk file, automatic acknowledgment upon return to normal of alarm condition, mandatory user acknowledgment of alarms.
- 10) Shall provide for Digital Alarm handling and allow a textual description field and voice, text, and email files for each Digital Alarm. Standard alarm acknowledgment requires personal involvement.
- 11) Shall allow for the creation and maintenance of "reports" or organized collections of tags. Such reports may be Voice accessed via smart phone app a mandatory password protection system. The report feature shall make it possible to inquire and receive a report of the description of the tag requested, along with the current value. This alteration process calls for the pre-configuration of the tag, making it available for inquiry and/or change.
- 12) Execution Software
  - a) Shall be capable of displaying on screen, current alarm status and alarm history status of a minimum of 500,000 simultaneous alarm tags.
  - b) Shall allow for manual transmission of user entered email, text or voice message by selection of destination from the phone book and message entry.
  - c) Shall be capable of maintaining a group by group activity log which may capture: Any alarms that may occur (along with user configurable time and date stamp), any return to normal transactions, any text and email messages, any voice dial-outs, any voice-dial-ins (including who has accessed the system and who has acknowledged alarms).
  - d) Historical data collection of all alarm events, alarm acknowledgements, and return-to-normal events. Line and bar graphs are used to present level and control data in a user friendly format and can be exported at any time to other 3<sup>rd</sup> party software packages
  - e) No other special hardware or software is required for system operation.

### **3.03 Incoming Service and Lightning Arrestor**

- A.** The incoming service for the control system shall be 120 volt, 1 phase, 3 wire, 60 Hertz. A single phase lightning arrestor shall be supplied in the control system and connected to each line of the incoming side of the power input terminals. The arrestor shall protect the control system against damage as the result of transient voltage surges caused by lightning interference, switching loads and power line interference's. It shall begin shunting to ground at 500 volts maximum.
- B.** All metering shall be done ahead of the main disconnect and control panel. The meter shall be supplied and installed by the Contractor in accordance with local power company requirements.
- C.** The electrical service shall be provided by the utility. Electric meterbase shall be provided by the owner and installed in accordance with the requirements of the electric utility. A UL rated main disconnect switch, circuit breaker panel, conduit and wiring between the power company termination and the control panel shall be furnished and installed by the contractor. The power supply to the control panels shall be 120 volts, single phase, three wire, 60 Hertz.

### **3.04 15 VDC Power Supply**

- A.** A regulated 15 VDC power supply shall be provided for the radios and other monitoring system components as required. The power supply shall include a terminal block for incoming AC. The power supply shall be powered from a 120 VAC and include tapered charge type battery charging circuitry to maximize battery life. The power supply shall be rated at minimum of 2.0A @ 15 VDC.
- B.** The power supply system shall include (1) 12 Volt rechargeable battery sized to allow for 4 hours continued system operation during a power outage.
- C.** The Crystal Ball Plus™ power supply contains a fuse-protected, internal, loop power supply capable of providing loop power for up to (4) external 4-20mA, 2-wire loop powered devices.

### **3.05 Signal Transient Protection**

- A.** Transient protection shall be provided with all equipment to protect all instrumentation and telemetry devices either receiving or sending signals.
- B.** The transient protectors shall be 4000V optical isolators which shall effectively arrest most transients encountered in an instrumentation environment.

### **3.06 Enclosure**

- A.** NEMA 4X polycarbonate 12 X 10 X 4" . Includes stainless padlockable hasp(s)

### **3.07 Antennas**

- A.** The antenna for each location shall be selected based on the results of the cellular survey.

**B.** All antenna shall be provided and installed by the Contractor as per recommendations from OmniSite

1. The Systems supplier shall be responsible for installation, set-up, adjustment and tuning of the antenna to provide optimal communications for the system.
2. The antenna installation shall be external to the enclosure and shall be outdoors.
3. The Systems supplier shall utilize the Crystal Ball Plus™ built-in Radio Frequency signal meter during antenna installation to ensure that the antenna are installed for optimum signal reception.

**C.** The Contractor shall ensure that the cellular Network system work is properly interfaced with equipment and other work not furnished by the Systems supplier.

**D.** The Systems supplier shall install, make final connections to, adjust, test, and start-up the complete cellular and cloud based system.

## **Part 4: General Equipment Requirements**

### **4.01 Wiring**

**A.** All wiring shall be minimum 600 volt UL type MTW or AWM and have a current-carrying capacity of not less than 125% of the full load current. The conductors shall be in complete conformity with the national electric codes, state, local and NEMA electrical standards. For ease of servicing and maintenance, all wiring shall be color coded. The wire color code shall be clearly shown on the drawings, with each wire's color indicated.

**B.** All control wiring shall be contained within plastic/PVC wiring duct covers. Where dimensional constraints prevent the use of wiring duct, wires shall be trained to panel components in groupings. The wire groupings shall be bundled and tied not less than every 3 inches with nylon self-locking cable ties as manufactured by Panduit or equal.

**C.** Every other cable tie shall be fastened to the enclosure door or inner device panel with a cable tie mounting plate with pressure tape. Where wiring crosses hinged areas such as when trained from the inner device panel to the enclosure door, spiral wrap shall be used.

**D.** The installation of the equipment described herein is provided by the electrical contractor in accordance with the electrical specification section of this project, and according to the detailed project drawings. Final equipment test, supervision and certification supplied by OmniSite trained representative.

### **4.02 NAMEPLATES**

**A.** All major components and sub-assemblies shall be identified as to function with laminated, nameplates.

## **Part 5: Execution**

**5.01            *Field Installation***

**A.** The services of a factory trained, qualified representative shall be provided to certify the completed system, make all adjustments necessary to place the system in trouble-free operation and instruct the operating personnel in the proper care and operation of the equipment.

**5.02            *Guarantee***

**A.** All equipment shall be guaranteed against defects in material and workmanship for a period of one year from the date of Owner's final inspection and acceptance to the effect that any defective equipment shall be repaired or replaced without cost or obligation to the Owner.

# OmniSite

## Cellular Remote Monitoring Device Crystal Ball Pump Analyzer and Backup Pump Controller - Interface Connections

Any signal 12 VDC/VAC through 120 VDC/VAC. No polarity required. Typical for Inputs 1-14.

**NOTE:** Different voltages can be applied to different input channels as needed (i.e. don't all have to be the same voltage)

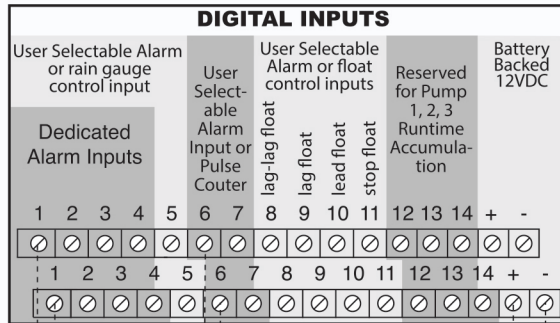
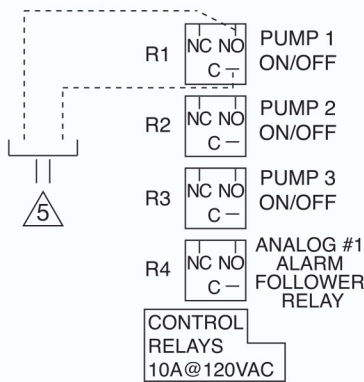

**Note: Field Installed Jumpers**

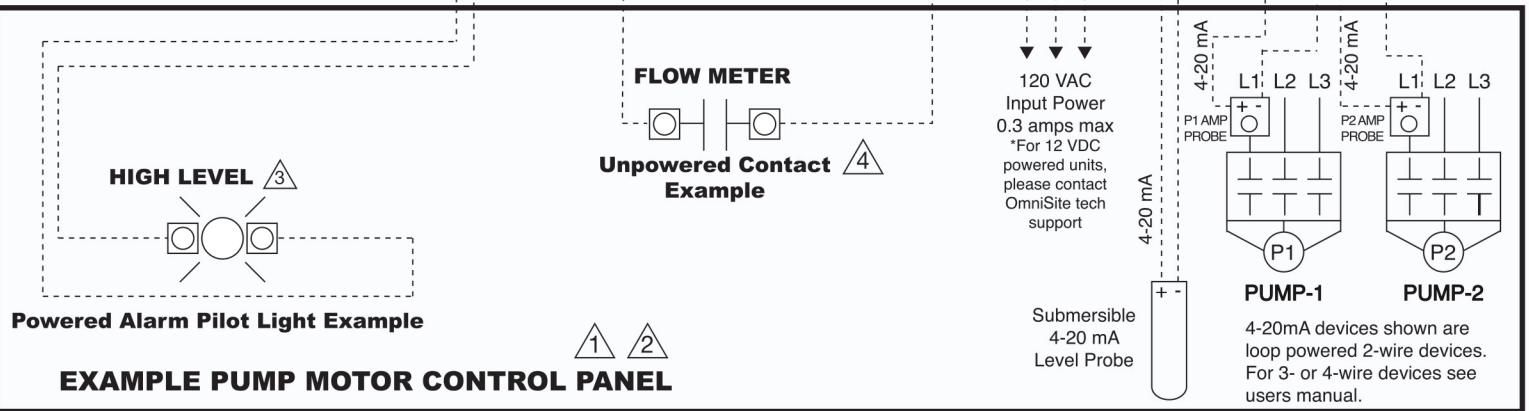
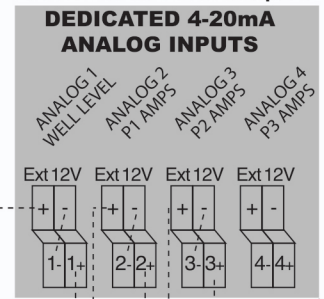

Note your input settings in the table below for reference

Input List			
Input	Description	Normal State:	
		OFF	ON
1			
2			
3			
4			
5			
6			
7			
8			
9			
10			
11			
12	PUMP 1 RUNTIME	X	X
13	PUMP 2 RUNTIME	X	X
14	PUMP 3 RUNTIME	X	X

### Ask About the OmniAdvantage Plan

- Lifetime Product Warranty
- Lifetime Radio Upgrades
- Free Software Upgrades
- Advanced Features on GuardDog 2 Mobile App
- GuardDog Setup & Priority Support
- Professional Training

**Contact:** (317)-885-6330 X4 or visit [www.omnisite.com/omniadvantage](http://www.omnisite.com/omniadvantage) for more details

## Notes

- 1 This drawing is to be used for general information only. The control system supplier must determine proper connections to the OmniSite panel for each application.
- 2 Dashed lines indicate external field wiring by contractor.
- 3 This example shows connection to the high level alarm pilot light. The recommended procedure is to connect OmniSite field input terminals in parallel with alarm pilot lights as shown for fast, easy connections. This can be repeated for any other alarm pilot lights to be mounted on the other inputs.
- 4 This example shows connections to a flow meter pulse contact. If you are monitoring unpowered, dry contacts, you must use a voltage source to power the contacts so the OmniSite unit can see them change state. This example shows using the onboard 12 VDC OmniSite power supply to power any number of dry contacts available. **CAUTION:** If you accidentally connect the onboard OmniSite 12 VDC power supply to contacts that have 120 VAC, you will cause non-warranty product damage.
- 5 Connect normally open relay contact to respective motor starter hand-off-auto control switch. Connect into auto circuit of switch.
- 6 Use shielded cable for 4-20mA inputs. Ground shield at Crystal Ball and tape-off at field device.

### SAFETY FIRST:

Always power off control panel and OmniSite unit when making wiring connections to avoid electrocution or accidental damage.

Typical Wiring Diagram for a Crystal Ball Monitoring Device to a Pump Control Panel

**OmniSite**  
203 W. Morris Street  
Indianapolis, IN 46225  
(317)-885-6330 | [www.omnisite.com](http://www.omnisite.com)

# OMNISITE CRYSTAL BALL DIMENSIONS

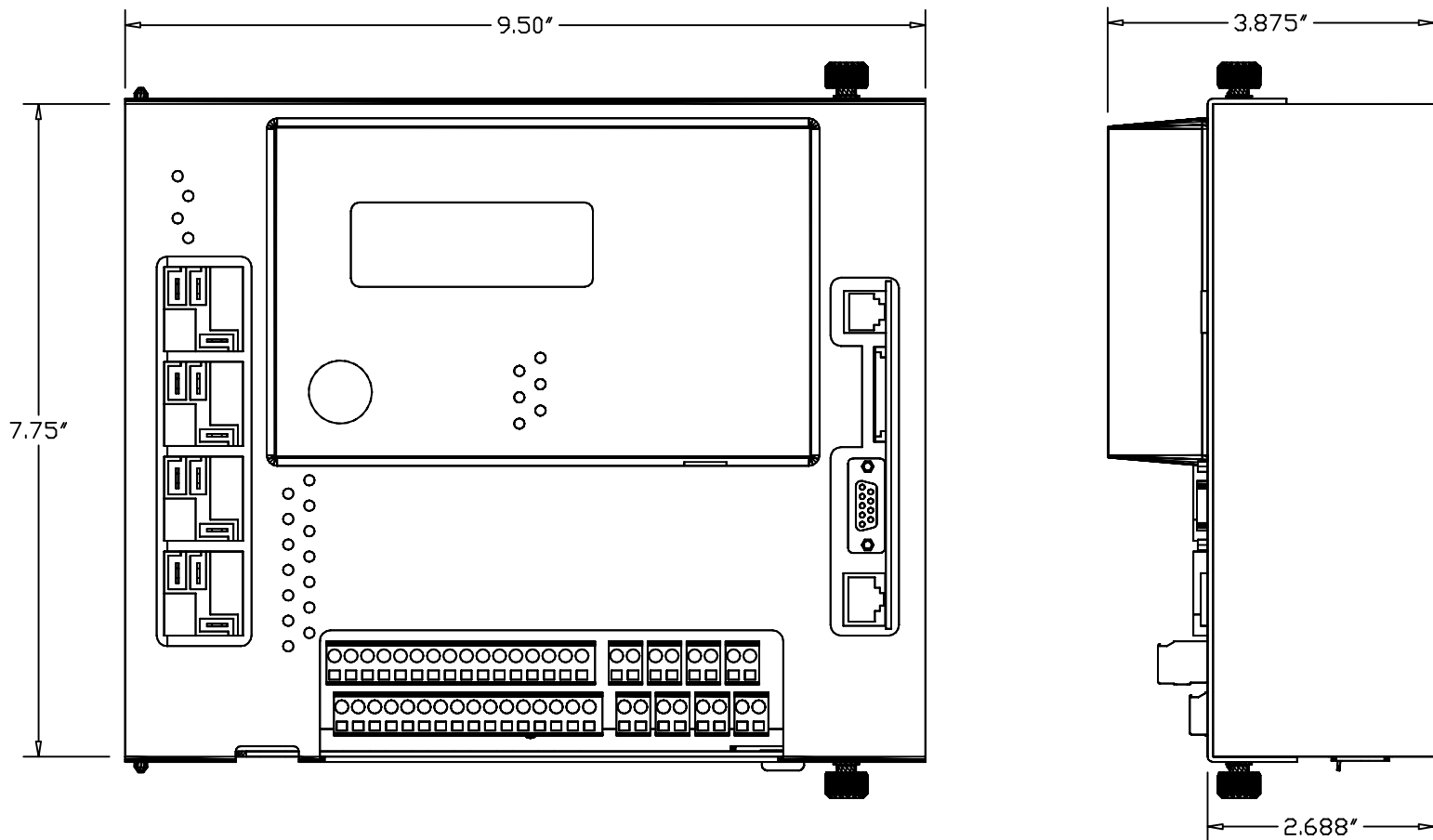

## MOUNTING DIMENSIONS

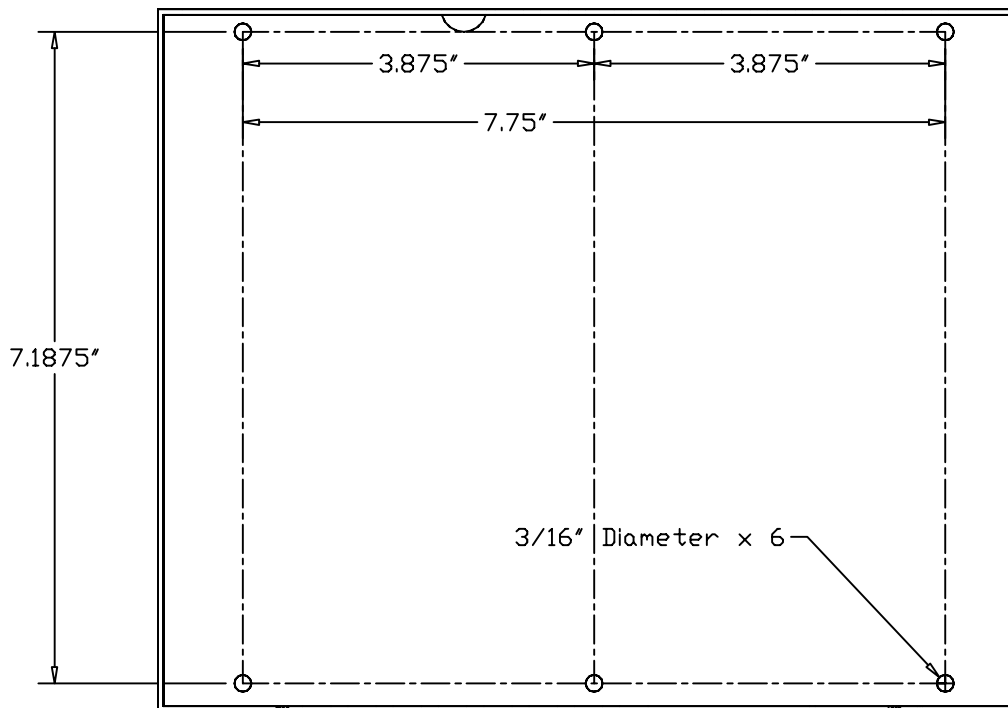

2

1

B

B

A

A

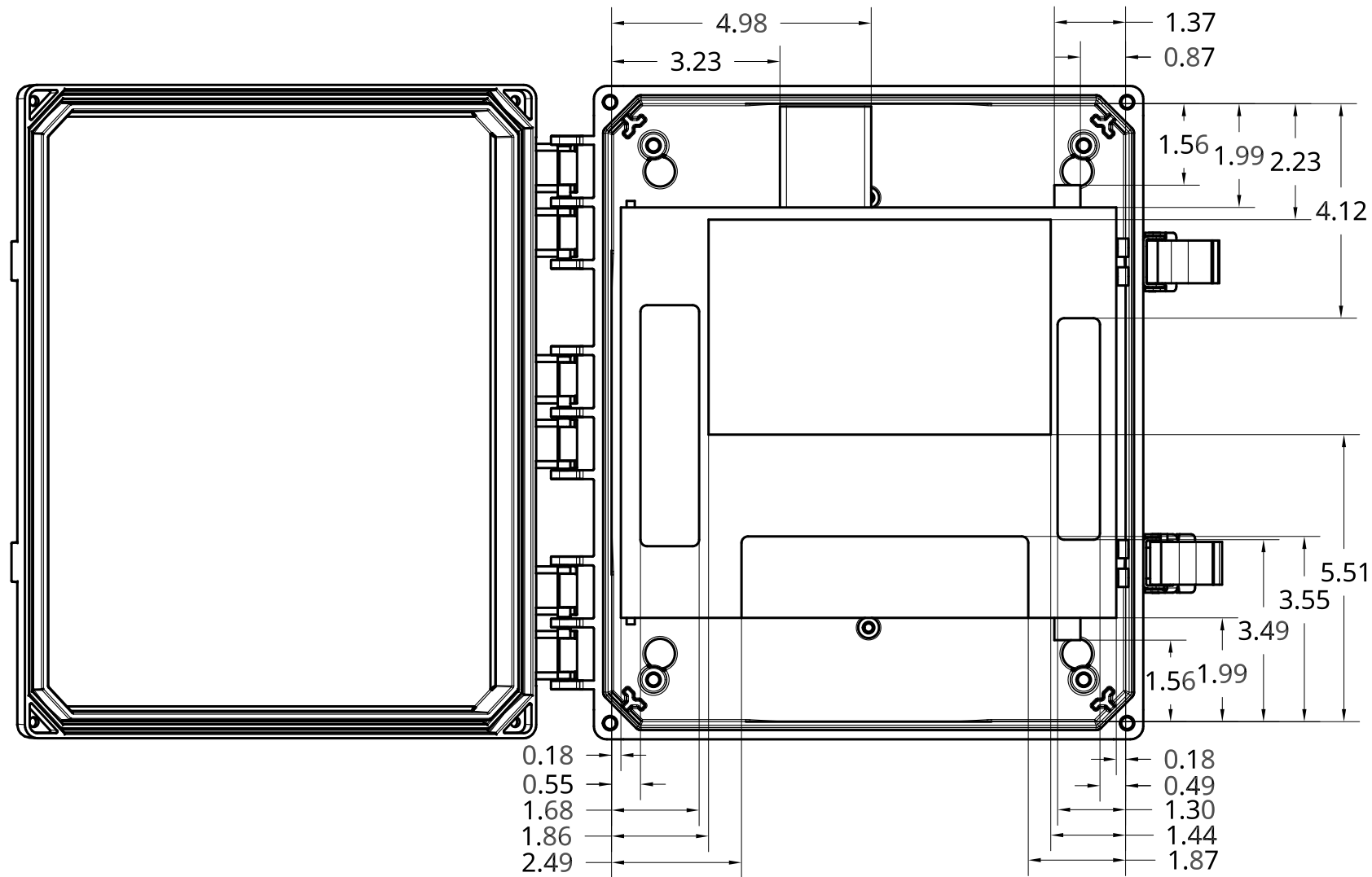

2

1

2

1

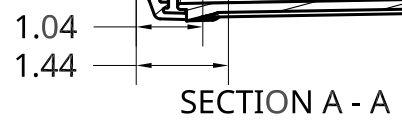
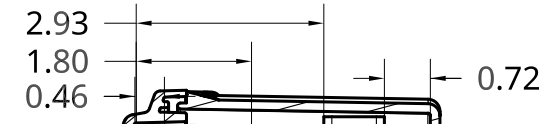
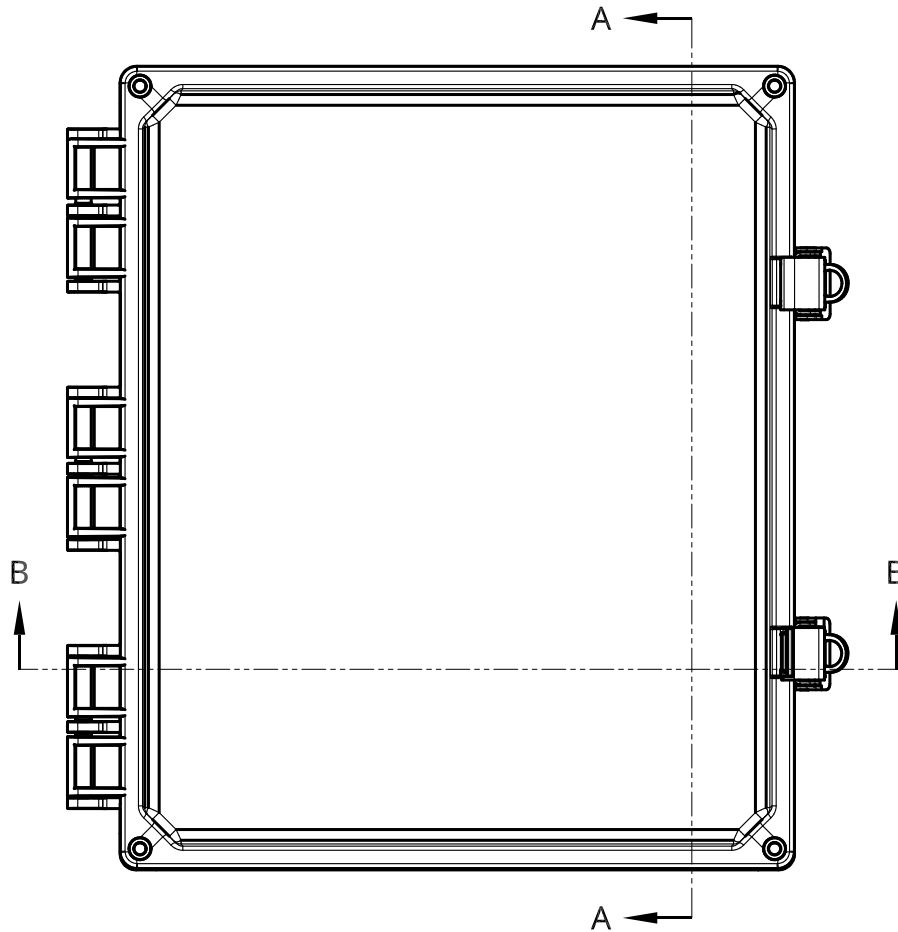

SECTION A - A

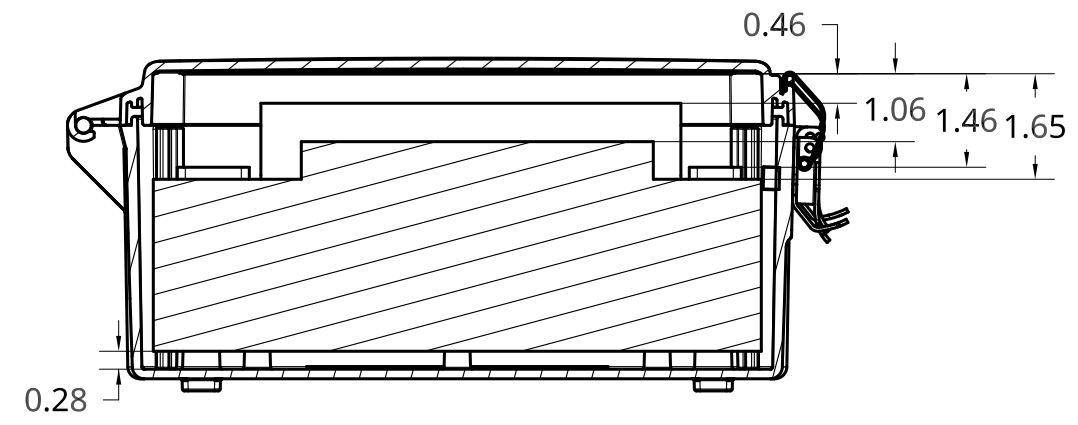

SECTION B - B

2

1